

Type RMB 1.4Y4-PAR

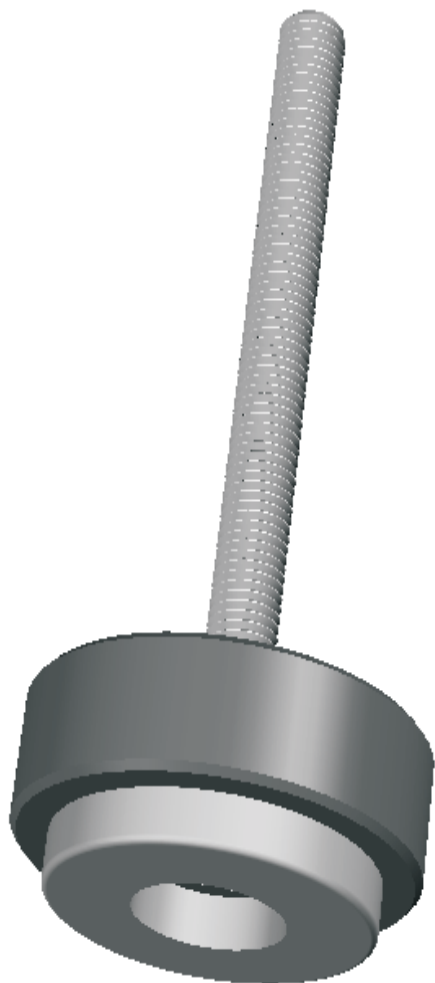

Technical Characteristics:

- Flexible support in mesh of stainless steel.
- Capacity to absorb compression loads
- Natural frequency = 14 ~ 21Hz
- Ideal deflection = 3mm
- Maximum deflection = 6mm
- Maximum impact = 3,5G

Constitute Characteristics:

- Mesh of stainless steel 316.
- Metal parts in steel SAE 1020.
- Screw in steel SAE 1020.
- Total weight = 1,3Kg

Applications:

- Exhaust gas piping system in vessels.
- Piping with high temperatures or large deflections.

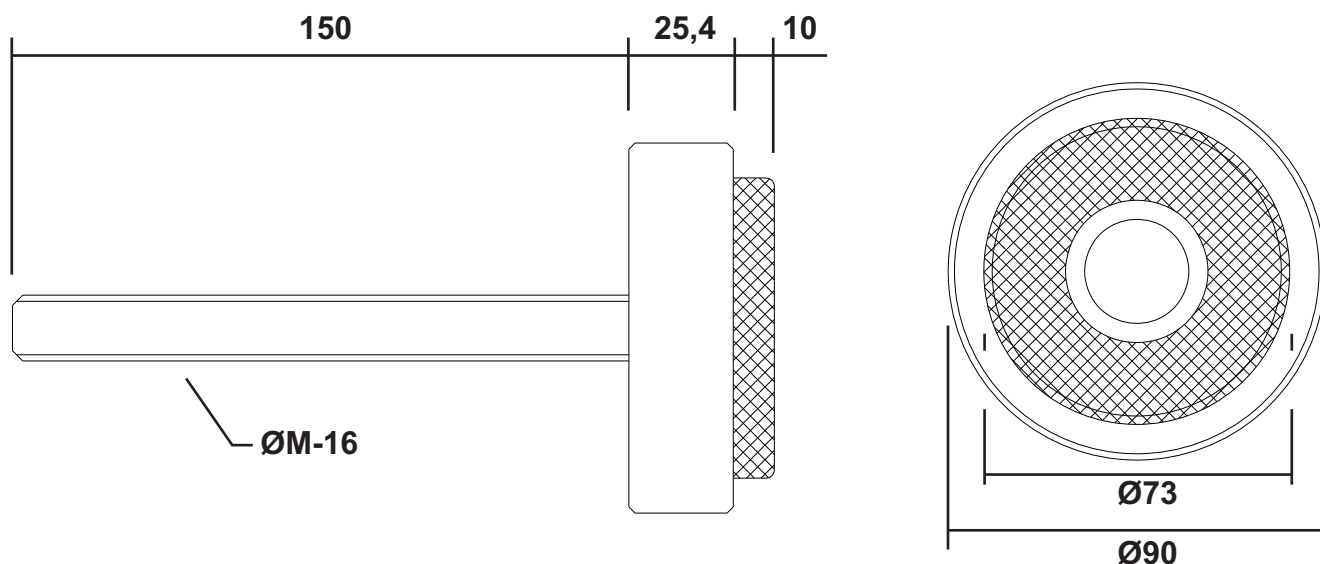

RISASPRINGS AMORTECEDORES DE VIBRAÇÃO LTDA.

Vendas: (55 11) 2459-3884 / 2453-5592 / 2453-2234 / 5572-7711

site: www.risasprings.com.br // e-mail: vendas@risasprings.com.br